



## Broaster<sup>®</sup> SmartTouch<sup>™</sup> Ventless Fryer—VF-2



### Standard Features

- *Easy to operate* – SmartTouch<sup>™</sup> Touch screen controller features a large, full color, touch screen display with easy to navigate menu and ability to pre-program up to 100 menu items.
- *Unique Auto-Comp<sup>™</sup>* – automatically adjusts cooking time to accommodate for varying sizes and temperatures of loads.
- *Space-Saving design* for back-counter operation.
- *Specifically designed for convenient production* – cooks up to 2 pounds per load.
- *Built-in fire suppression system* in accordance with NFPA 17A and resettable high temp limit switch for added safety.
- *No hood required in most municipalities.*
- *HEPA and charcoal 2-stage air filter cartridge for ventless operation.*
- *Easy to clean* – all interior components are easily removed and dishwasher safe.
- *Proven round cooking well design* – engineered for more uniform heat distribution, durability, and efficiency; no cold spots or corners.
- *Auto-Lift* ensures consistent product output by automatically lowering the cooking basket at the beginning of the cook cycle and raising the basket at the end.



### Specifications

Model VF-2 ventless fryer includes round cooking well with 14 pound cooking oil capacity. Unit is primarily stainless steel monocoque construction with black, welded and powder-coated steel base plate. Interior cooking well tray is designed to capture spills up to 15 cups. Heating element is fully immersible with lift-and-lock mechanism for easy cleaning.

SmartTouch Touch Screen Controller provides a programmable library with pre-loaded menu items and an automatic cook-cycle counter. Auto-comp feature automatically adjusts cooking time to accommodate for varying sizes and temperatures of load. On-screen prompts assist users in operation and maintenance functions.

Unit is fitted with the following additional safety features: integrated ANSUL fire suppression system including on-board canister and two fusible links in cooking and

air-handling zones to meet NFPA 17A standards; redundant electrical controls managed by two interlocked contactors; fail safe high-limit thermostatic control with manual and remote reset features.

Three-stage air filtration system is powered by a ball bearing radial blower moving 55 CFM of air through the cooking chamber. System includes an easily removable and washable centrifugal grease extraction and flame suppression filter. There is also a two stage replaceable air filter cartridge. Filter cartridge captures over 80% of allowable particulate emissions and includes high grade HEPA media and activated carbon.

Equipment is covered by manufacturer's 1 year parts and labor warranty on all systems with additional 1 year on controller parts.

# Broaster® SmartTouch™ Ventless Fryer—VF-2

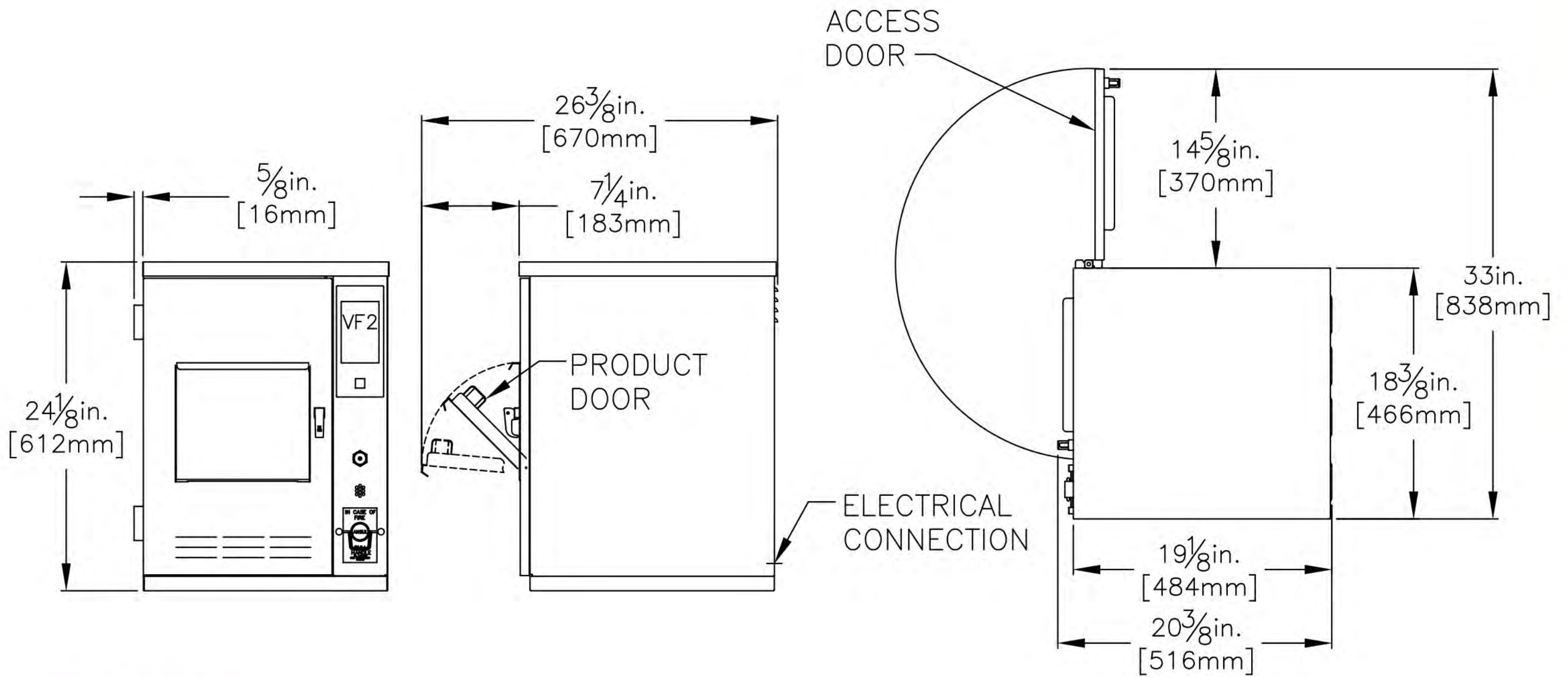

## Dimensions

Model	Capacity	Cooking Oil Capacity	Overall Dimensions			Net/Ship Weight
			W	D	H	
VF-2 208v:85899 240v:85900	2 lbs./load (.91 kg/load) (approx. 16, 2 oz. tenders)	14 lbs./1.85gal. (6.35 kg/7.0L)	18-3/8" (466 mm)	19-1/8" (484 mm)	24-1/8" (612 mm)	97/148 lbs. (44/67.1 kg)

## Energy Requirements

**VF-2** 5.5kW Rated Heating Elements

- 1 phase, 120/208 volt, 60 hz, 27 amps
- 1 phase, 120/240 volt, 60 hz, 23 amps

4-wire with ground and neutral  
No cord/plug provided.  
(To be field wired according to ANSI/NFPA 70 or CSA C22.2)

## Additional Features

- Energy Savings Idle mode and auto shut-off.
- Information Center provides at-a-glance monitoring of all critical systems.
- Convenient front product door for ease of loading and unloading.
- Oil level “dipstick” to insure proper cooking levels.
- Coated basket handle for operator comfort and safety.

## Complete Start-up Accessory Kit



## Accessories & Options Available

- Removable basket cover to keep products submerged while cooking
- Complete Start-up accessory kit



**TSBLDIST.COM | 651-348-1007 | Justinl@tsbldist.com**